

COME TO THE SOURCE



GP-44SP

SMALL PACKAGE

Automatic Strapping Machine



The GP-44SP Small Package Automatic Strapping Machine. Designed specifically for tight strapping of narrow bundles and packages. The GP-44SP offers the highest quality, reliability, simplicity and safety.

The Best Choice...The Only Choice

GP-44SP *Small Package* Automatic Strapping Machine

- Capable of up to 30 straps per minute
- Programmable controlled with limited diagnostics
- Outside reel with automatic, waist-high strap loading
- Electric, no-adjust reel brake
- Movable, magnetic control box to facilitate any operation position
- Safety switches on table tops and front door
- Loop ejector to eject accidentally actuated straps
- Long life heater blade with smoke exhaust system
- Power savings system. Motors run only during strap cycle
- Outside tension adjust knob
- Portable on casters
- Choice of 3/8" or 1/2" strap. Available with 8"x8" or 9"x8" core
- Seven digit, non-reset maintenance counter
- Stainless steel table top
- Automatic re-feed mechanism



Specially designed to strap narrow packages.



*Waist-high, Automatic Strap Loading
Simple Diagnostics*

Great for wood molding or trim.

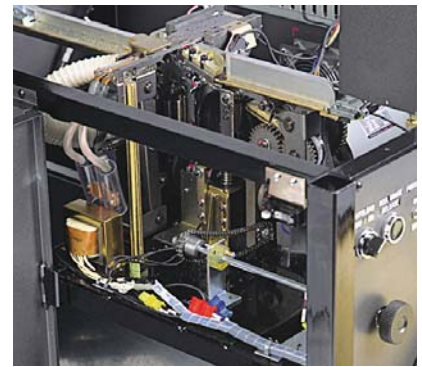

Simple Seal Engine. Minimal Parts.

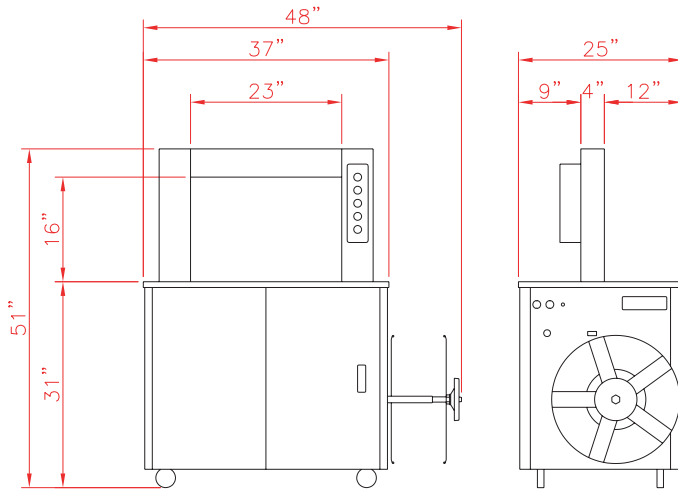

SPECIFICATIONS

Model:	GP-44SP
Speed:	Up to 30 straps per minute
Power:	110 volt single phase, others available
Tension:	External, fully adjustable range
Strap Sizes:	3/8" or 1/2" on 8"x8" or 9"x8" core
Arch Size:	23"high x 16"high
Weight:	462 lbs.
Table Top Height:	31", adjustable height available
Min. Package Size:	3"wide x 3"high incompressible
Options:	Adjustable Casters Adding 3" to starting Height

***NOTE:** Strapping cycle time varies with arch size and package size



6277 HEISLEY ROAD
MENTOR, OHIO 44060
(440) 357-1500
FAX (440) 352-9553
1-800-548-9557

WEST COAST DISTRIBUTION CENTER
12332 BELL RANCH DRIVE
SANTA FE SPRINGS, CA 90670
(562) 903-4576
FAX (562) 903-4579
1-800-899-0822